



CONDUIT AND JUNCTION BOX REQUIREMENTS FOR I062ix

- ① 25mm (1") METAL CONDUIT FROM ALARM CONTROL CABINET JUNCTION BOX TO 102mm(4") SO. X 54mm(2 1/8") DP. JUNCTION BOX (ALL BY E.C.) DIEBOLD TO PROVIDE FLAT COVER WITH TAMPER SWITCH.
- ② WHEN "SECUROMATIC" AFTER HOUR DEPOSITORY IS TO BE CONNECTED TO ATM UNIT, E.C. TO RUN 19mm (3/4") METAL CONDUIT FROM 102mm (4") SO. X 54mm(2 1/8") DP. JUNCTION BOX TO AFTER HOUR DEPOSITORY.
- ③ E.C. TO RUN 19mm (3/4") LIQUID TIGHT FLEX METAL CONDUIT OR 19mm(3/4") RIGID CONDUIT FROM JUNCTION BOX TO CABLE CONNECTING PLATE.
- ④ 19mm (3/4") METAL CONDUIT AND UNSWITCHED ELECTRICAL SUPPLY TO 102mm(4") SO. X 54mm (2 1/8") DP. JUNCTION BOX WITH RECEPTACLE WITHIN 2184mm (86") OF SIDE OR FRONT CONNECTING PLATE. BOTTOM CONNECTION MUST BE COMPENSATED ACCORDINGLY (ALL BY E.C.) (SEE POWER REQUIREMENTS).
- ⑤ E.C. TO SUPPLY COMPATIBLE RECEPTACLE FOR COUNTRY SPECIFIC PLUG-IN CONNECTOR SUPPLIED WITH UNIT. POWER CORD LENGTH 2184mm (86") FROM SIDE OF UNIT.

NOTE:

JUNCTION BOXES MUST BE LOCATED WITHIN 2184mm (86") OF CONNECTING PLATE. (LENGTH OF ELECTRICAL POWER CABLE PROVIDED WITH UNIT). LOCATE IN AN EASILY ACCESSIBLE AREA.

BOXES CAN BE FLUSH MOUNTED WITH CONCEALED CONDUIT FOR NEW CONSTRUCTION OR BOXES CAN BE SURFACE MOUNTED WITH EXPOSED CONDUIT FOR EXISTING CONSTRUCTION.

CONDUIT AND JUNCTION BOX REQUIREMENTS FOR I040 ETC

- ① 19mm (3/4") METAL CONDUIT AND UNSWITCHED ELECTRICAL SUPPLY TO 102. (4") SO. X 54mm (2 1/8") DP. JUNCTION BOX WITH RECEPTACLE WITHIN 1778mm (70") OF SIDE CONNECTING PLATE. BOTTOM CONNECTION MUST BE COMPENSATED mm ACCORDINGLY (ALL BY E.C.) (SEE POWER REQUIREMENTS).
- ② E.C. TO SUPPLY COMPATIBLE RECEPTACLE FOR COUNTRY SPECIFIC PLUG-IN CONNECTOR SUPPLIED WITH UNIT. POWER CORD LENGTH 1778mm (70") FROM SIDE OF UNIT.

NOTE:

JUNCTION BOX MUST BE LOCATED WITHIN 1778mm (70") OF CONNECTING PLATE. (LENGTH OF ELECTRICAL POWER CABLE PROVIDED WITH UNIT). LOCATE IN AN EASILY ACCESSIBLE AREA.

BOX CAN BE FLUSH MOUNTED WITH CONCEALED CONDUIT FOR NEW CONSTRUCTION OR BOX CAN BE SURFACE MOUNTED WITH EXPOSED CONDUIT FOR EXISTING CONSTRUCTION.

ALARM PROTECTION

THE CABINET IS EQUIPPED WITH A BASIC ALARM SENSOR PACKAGE. THE BASIC PACKAGE INCLUDES A CABINET DOOR OPEN SWITCH AND ALARM SHUNTING SWITCH.

FOR DESK TOP MODEMS- NO CONDUIT REQUIRED FOR DATA LINE CABLE. MODEM MUST BE INSTALLED WITHIN 12802mm (42'-0") CABLE RUN OF THE UNIT.

DATA CABLE MUST BE AT LEAST 51mm (2") FROM ANY A.C. POWER CABLE.

DESK TOP MODEMS MUST BE WITHIN 1828mm (6'-0") OF A STANDARD, SINGLE PHASE, THREE-WIRE OUTLET.

POWER REQUIREMENTS

THE I040 ETC REQUIRES A SINGLE-PHASE THREE-WIRE UNSWITCHED POWER OUTLET. WIRING TO THE I040 ETC MUST USE A THIRD-WIRE EARTH GROUND (CONDUIT GROUND IS NOT ACCEPTABLE). THE POWER SUPPLIED MUST BE AS SPECIFIED BELOW:

- 100-127 VAC (+6%,-10%) 50HZ (+/-1%) SINGLE PHASE
- 100-127 VAC (+6%,-10%) 60HZ (+/-1%) SINGLE PHASE
- 200-240 VAC (+/-10%) 50HZ (+/-1%) SINGLE PHASE
- 200-240 VAC (+/-10%) 60HZ (+/-1%) SINGLE PHASE

POWER TO THE I040 ETC MAY BE A BRANCH OR DEDICATED SERVICE AND MUST BE PROTECTED BY A SAFETY QUICK-DISCONNECT DEVICE TO BREAK LINE VOLTAGE (SUCH AS A CIRCUIT BREAKER AT THE ELECTRICAL SERVICE PANEL). THE QUICK DISCONNECT DEVICE (OR CIRCUIT BREAKER) MUST TURN OFF THE LINE VOLTAGE AT THE AMPERAGE SPECIFIED BELOW.

- 100-127 VAC SERVICE, DISCONNECT AT 20 AMPERES
- 200-240 VAC SERVICE, DISCONNECT AT 10 AMPERES

OTHER ELECTRONIC DEVICES SHARING POWER ON A COMMON BRANCH CIRCUIT MUST CONFORM TO THE SAME CONDUCTED INTERFERENCE STANDARDS AS THE ATM AND I040 ETC.

POWER USAGE FOR I040 ETC

MACHINE STATUS	① SYSTEM CONFIGURATION
IDLE (NO TRANSACTION)	70 WATTS
TRANSACTION (DISPENSE) IN PROGRESS	135 WATTS

- ① INTELLIGENT DEPOSITORY, CARD DISPENSER, MONEY ORDER PRINTER AND CASH ACCEPTOR

HEAT OUTPUT

200 BTU/HR MAX. (DISPENSE) - 170 BTU/HR (IDLE)

OPERATING ENVIRONMENT

SAFE LOCATION ————— 10°C TO 38°C (50°F TO 100°F)
RELATIVE HUMIDITY (NON-CONDENSING)
20 TO 80% AT 32°C (90°F),
20 TO 55% AT 38°C (100°F)

WEIGHT OF UNIT

195 kg (430 LBS.)

DIMENSIONS IN MILLIMETRES (DIMENSIONS IN INCHES)

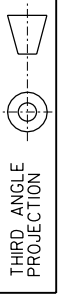

PAGE 2 OF 4

ALL DIMENSIONS AND DESIGN CRITERIA SUBJECT TO CHANGE WITHOUT NOTICE.

FILE NO. I77-446 REV. 0

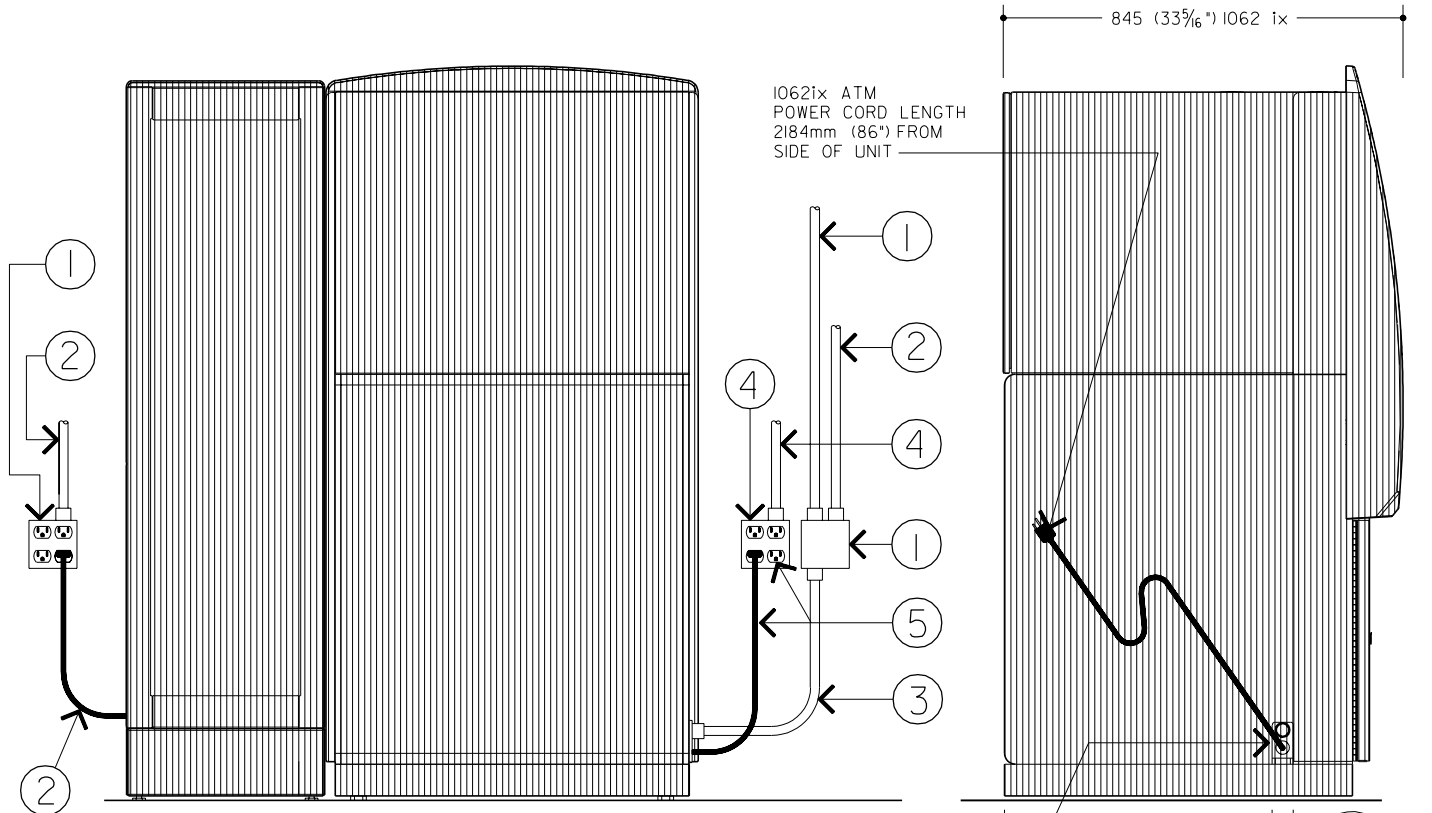

BACK VIEW

SIDE VIEW

CALL 1-800-999-3600

GENERAL SPECIFICATIONS

SIGNAL CABLE RUN CONSTRAINTS

THE FOLLOWING CHART ITEMIZES THE PHYSICAL SPACING REQUIREMENTS OF THE SIGNAL CABLE RUN WITH RESPECT TO OTHER POWER AND ELECTRICAL EQUIPMENT CABLE RUN.

TYPE OF ELECTRICAL RUN	POWER OF ELECTRICAL RUN		
	BELOW 2 KVA	2-5 KVA	ABOVE 5 KVA
FLUORESCENT, NEON OR INCANDESCENT LIGHTING FIXTURES	125 mm (5")	125 mm (5")	125 mm (5")
UNSHIELDED POWER LINE OR ELECTRICAL EQUIPMENT	305 mm (12")	305 mm (12")	610 mm (24")
UNSHIELDED POWER LINES OR ELECTRICAL EQUIPMENT WITH SIGNAL CABLES ENCLOSED IN GROUNDED CONDUIT	64 mm (2½")	152 mm (6")	305 mm (12")
POWER LINES IN GROUNDED CONDUIT WITH SIGNAL CABLES IN GROUNDED CONDUIT	30 mm (¾")	76 mm (3")	152 mm (6")

SIGNAL CABLE INSTALLATION CONSTRAINTS

RELATIVE CARE IS REQUIRED WHEN INSTALLING SIGNAL CABLES IN CONDUITS. UNLIKE POWER AND LIGHTING CABLE, SIGNAL CABLES HAVE SMALL CONDUCTORS AND LIGHT INSULATION AND WILL NOT WITHSTAND AS MUCH STRAIN IN INSTALLATION. THE FOLLOWING CHART SUMMARIZES SOME COMMON CONDUIT PARAMETERS. THE SUM OF THE CROSS-SECTIONAL AREAS OF CABLES BEING INSTALLED IN CONDUIT SHOULD NOT EXCEED 40% OF THE AREA OF THE CONDUIT.

CONDUIT SIZE (INCHES)	INTERNAL DIAMETER (INCHES)	AREA-SQUARE INCHES			
		100%	40%	33%	25%
½"	.622	.30	.12	.099	.075
¾"	.824	.53	.21	.175	.132
1"	1.049	.86	.34	.283	.215
1¼"	1.380	1.50	.60	.495	.375
1½"	1.610	2.04	.81	.673	.510
2"	2.067	3.36	1.34	1.109	.840

FOR CONDUIT RUNS 15.25 METRES TO 30.5 METRES (50 TO 100 FEET), NOT MORE THAN 33% OF CONDUIT AREA SHOULD BE USED.

FOR CONDUIT RUNS OVER 30.5 METRES (100 FEET), NOT MORE THAN 25% OF CONDUIT AREA SHOULD BE USED.

EACH 90° CONDUIT BEND MAY BE ESTIMATED AS EQUAL TO THE FRICTION OF A 9.15 METRES (30 FOOT) LENGTH STRAIGHT LEVEL CONDUIT. IF MORE THAN TWO 90° BENDS ARE USED IN CONDUIT RUN, INSERT A PULL BOX.

ELECTRO STATIC DISCHARGE

STATIC ELECTRICITY CHARGES ARE BUILT-UP AS A RESULT OF CONTACT WITH CERTAIN FLOOR COVERINGS AND FURNITURE. A DISCHARGE OF THIS BUILD-UP CAN CAUSE DISCOMFORT TO PEOPLE AND POSSIBLE INTERFERENCE WITH ELECTRONIC EQUIPMENT. THE FOLLOWING PRECAUTIONS SHOULD BE TAKEN WHENEVER POSSIBLE TO REDUCE THE CHANCE OF STATIC DISCHARGE PROBLEMS.

AVOID RELATIVE HUMIDITY VALUES OF LESS THAN 40%. TREAT FLOOR COVERINGS AROUND ELECTRONIC EQUIPMENT WITH STATIC REDUCING AGENTS COMMERCIALY AVAILABLE.

EXTERNAL CABLING

PLEASE REFER TO THE APPROPRIATE ATM LITHO FOR DETAILS FOR TERMINAL CABLE ACCESS. JUNCTION BOXES, CONDUIT, ETC., ARE THE RESPONSIBILITY OF THE CUSTOMER AND ARE NOT SUPPLIED BY DIEBOLD. LOCAL CODES WILL DICTATE LOCATION AND MATERIALS TO BE USED IN ELECTRICAL CONNECTIONS.

DIMENSIONS IN MILLIMETRES
(DIMENSIONS IN INCHES)



THIRD ANGLE
PROJECTION

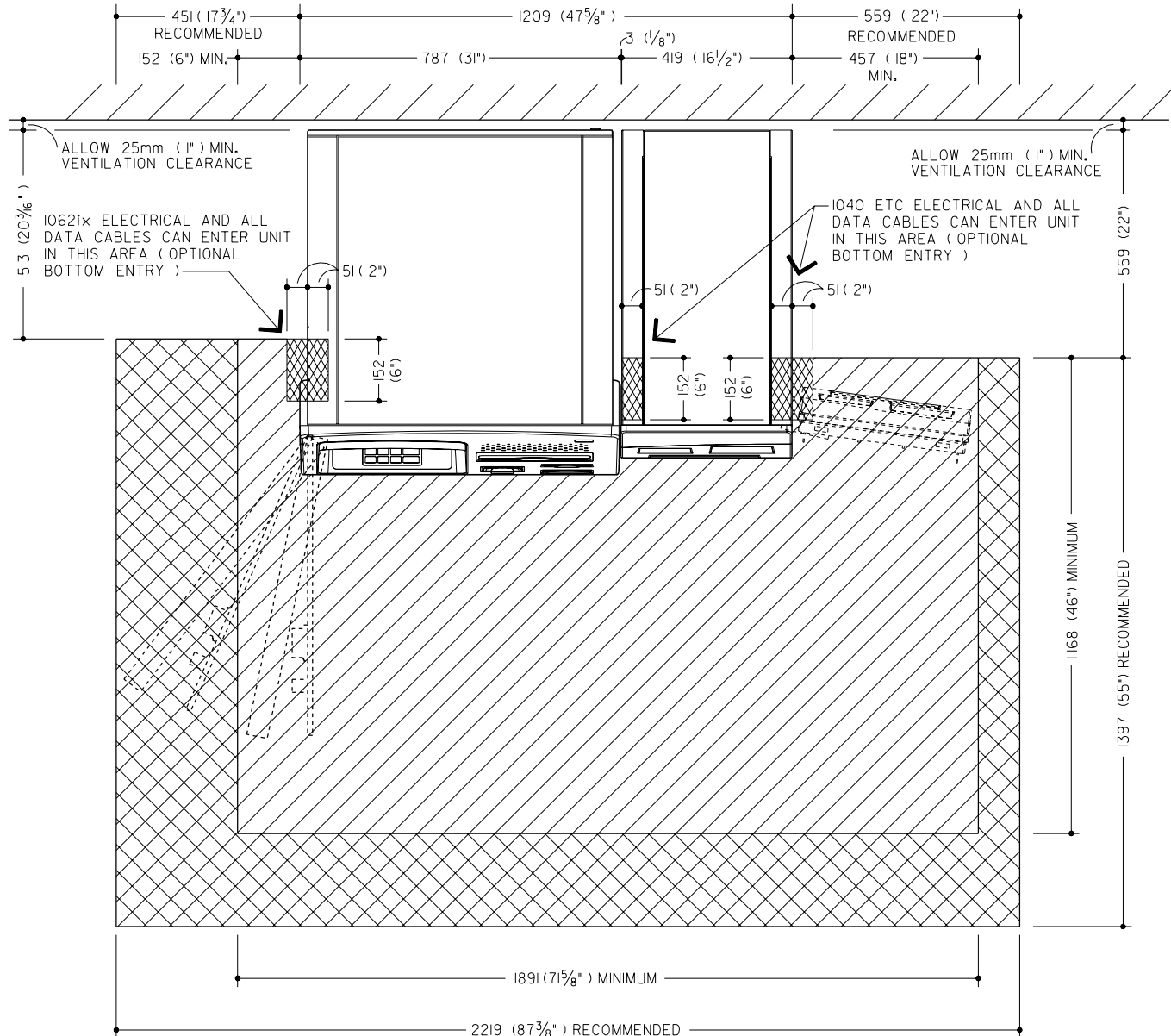

DIMENSIONS IN MILLIMETRES
(DIMENSIONS IN INCHES)

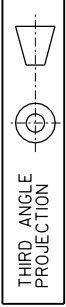

PLAN VIEW

- MINIMUM SERVICE AREA
- RECOMMENDED SERVICE AREA
- ELECTRICAL AND DATA CABLES CAN ENTER UNITS IN THESE AREAS (BOTTOM OR SIDE OF UNIT)

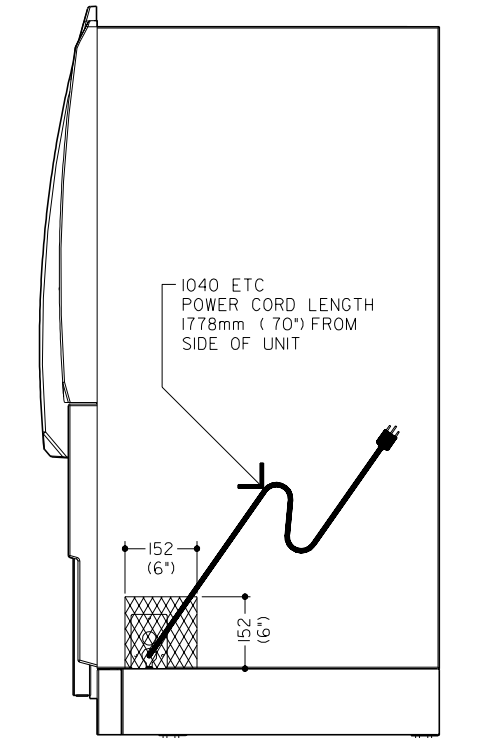

SIDE VIEW

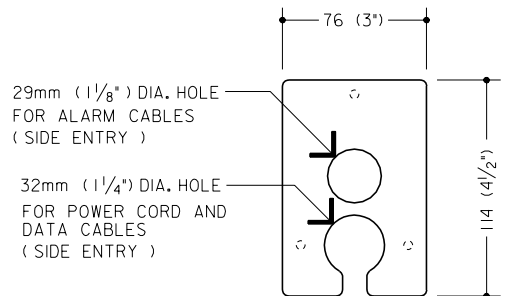

I040 ETC
POWER/DATA CABLE PLATE